

Green pump

Features and Strengths

Excellent hygiene products for food, pharma and chemical industry
Integrated vacuum filter with high dirt capacity
Single/Dual cartridge option selectable
Compact size and light weight

Advantages

Reliable and stable operation - High vacuum level and vacuum flow in efficient air consumption
Suitable in application where high level hygiene standard is needed in
Compact size and easy installation

Application

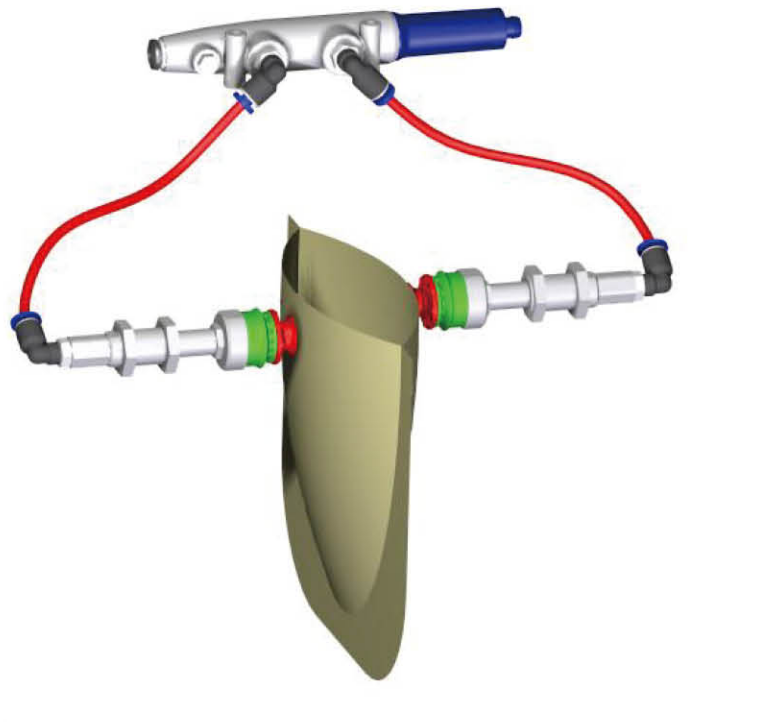



Recommended Lifting Force (Max.)

Model	Max. Vacuum level (- kPa)	Max. Feed Pressure (bar)	Max. Vacuum Flow (NI/m)	Air Consumption (NI/m)
GS203F	-90 kPa	4 bar	85 NI/min	32 NI/min
GS252	-94 kPa	6 bar	113 NI/min	83.5 NI/min
GS253F	-94 kPa	6 bar	146 NI/min	83.5 NI/min
GS302	-92 kPa	4 bar	171 NI/min	152 NI/min
GSL302	-75 kPa	6 bar	200 NI/min	104 NI/min
GH203F	-90 kPa	4 bar	172 NI/min	64 NI/min
GH252	-94 kPa	6 bar	222 NI/min	167 NI/min
GH253F	-94 kPa	6 bar	292 NI/min	167 NI/min
GH302	-92 kPa	4 bar	343 NI/min	304 NI/min
GHL302	-75 kPa	6 bar	400 NI/min	208 NI/min

VACUUM PUMPS / Green pumps

Green pump

VMECA Green pump with VMECA vacuum cartridge technology and integral vacuum filter is highly regarded as vacuum pump suitable for industries where high hygiene level standard such as food, pharma and chemical, etc. It has wide selection with various vacuum flow according to application with vacuum filter inside. Also size is compact so that it can be easily installed on limited space on machines.



Key advantages

- VMECA vacuum cartridge integrated with auto filter cleaning system
- Vacuum filter integrated
- High level hygiene level

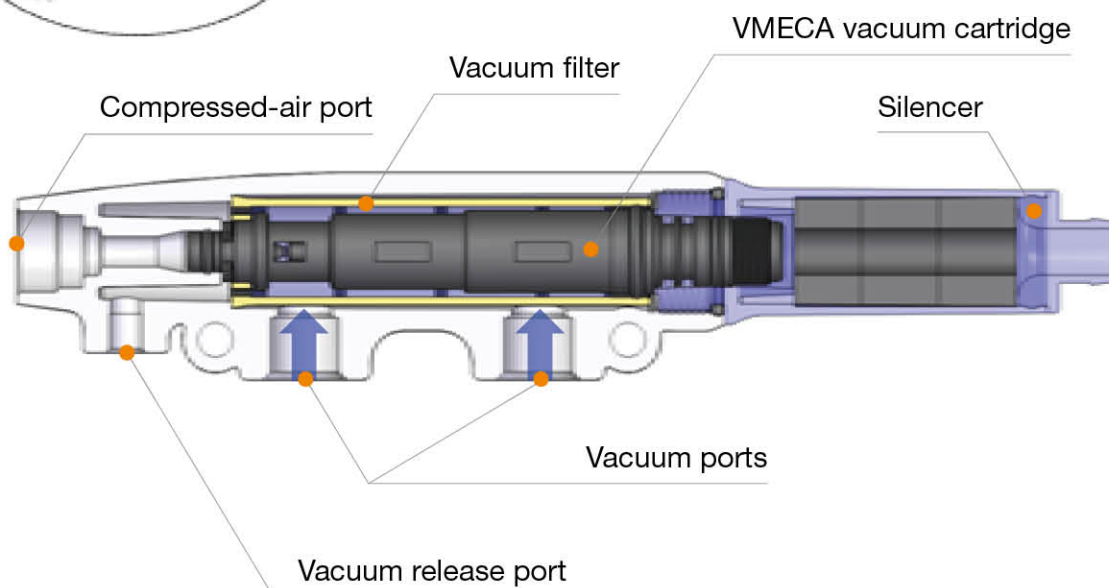

I Auto filter cleaning system

Patent &
Patent pending

Vacuum Release Air



- ✓ Prevent dust coming into the pump
- ✓ Use release flow, filtered dust can be cleaned every cycle automatically

I Filter window

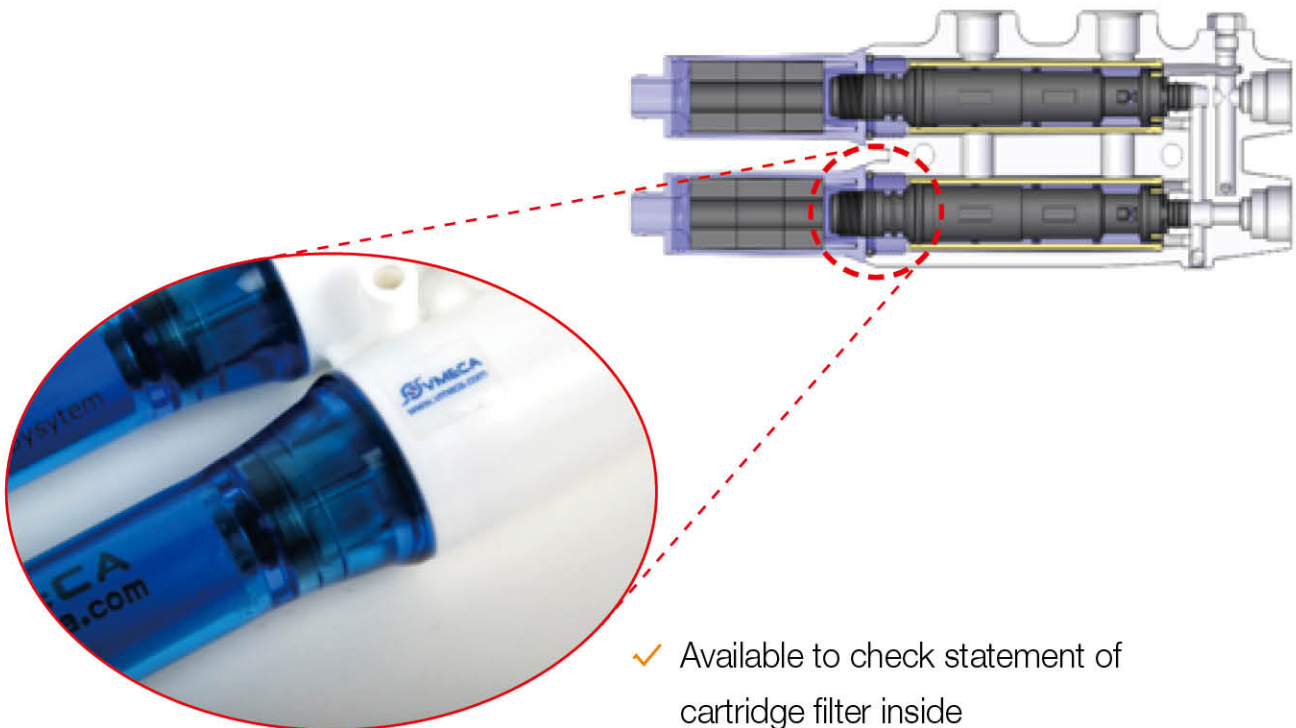

- ✓ Available to check statement of cartridge filter inside

VACUUM PUMPS / Green pumps

GS series

Features and Strengths

- Highly operational reliability despite fluctuating or low compressed-air pressure
- Integrated vacuum filter with high dirt capacity & Auto-cleaning system
- High polished clean surface for food, pharma and chemical industry
- Easy to install in limited space due to compact size
- Quick response time



Specifications

Description	GS203	GS252	GS253	GS302	GSL302
Max. Vacuum level	-90kPa	-94kPa	-94kPa	-92kPa	-75kPa
Open Vacuum flow	85 NI/min	113 NI/min	146 NI/min	171 NI/min	200 NI/min
Max. Feed pressure	4 bar	6 bar	6 bar	4 bar	6 bar
Temperature	-20 ~ 80	-20 ~ 80	-20 ~ 80	-20 ~ 80	-20 ~ 80
Noise level	52 ~ 58 dBA	60 ~ 68 dBA	60 ~ 68 dBA	60 ~ 68 dBA	60 ~ 68 dBA
Weight	0.05Kg	0.055Kg	0.100Kg	0.105Kg	0.105Kg

Vacuum Flow

Model	Max. vacuum (-kPa)	Feed Pressure (bar)	Vacuum flow (NI/min) at different vacuum levels (-kPa)									
			0	10	20	30	40	50	60	70	80	90
GS203	65	2.2	67.2	29.5	17	11.2	8	5.2	1.4	-	-	-
	90	3.2	85.6	36.9	26	15.8	11	8.9	6.6	3.9	2	-
	85	4.0	85.8	42.7	31	23	14.1	7.6	6.4	3.9	1.3	-
GS252	90	5.0	112	85	63	43	37	27	22	17	11	3.1
	94	5.5	113	91	69	48	30	26	22	17	11	2.8
	93.5	6.0	111	97	76.5	54	34	25	21	16	9.5	2.3
GS253	90	5.0	137	105	63	42	32.5	26	21	17	11	3.1
	94	5.5	141	109	71	51	32	26	22	17.5	11	2.8
	93.5	6.0	146	108	75	60	42	25	21	16	9.6	2.3
GS302	75	2.2	164	122.5	88	53	31.4	28.5	16.5	4.6	-	-
	92	3.0	170	152	106	64	31.5	32	22	16.5	6.4	1.9
	92	4.0	171	154	127	94	69	43	23	17	6.9	2.1
GSL302	60	4.0	188	158	110	70	46	28	6.8	-	-	-
	70	5.0	195	176	130	82	50	37	23	11.9	-	-
	75	6.0	200	183	154	100	52	38	32	22	-	-

I Evacuation Time

Model	Feed Pressure (bar)	Air Consumption (NI/min)	Evacuation time in sec / liter to reach different vacuum levels (-kPa)									
			0	10	20	30	40	50	60	70	80	90
GS203	2.2	21	0.08	0.38	0.8	1.47	1.9	2.4	-	-	-	-
	3.3	27	0.06	0.28	0.52	1.4	1.4	2	3.2	6	-	-
	4.0	32	0.075	0.26	0.49	0.8	1	1.8	3	6.8	-	-
GS252	5.0	70.5	0.039	0.15	0.27	0.49	0.60	0.94	2.09	2.82	4.83	3.1
	5.5	77	0.037	0.13	0.26	0.41	0.54	0.86	1.2	1.6	5	2.8
	6.0	83.5	0.035	0.078	0.12	0.13	0.33	0.83	1.15	1.76	5.8	2.3
GS253	5.0	70.5	0.034	0.136	0.23	0.43	0.52	0.82	1.82	2.46	4.22	3.1
	5.5	77	0.034	0.125	0.24	0.37	0.5	0.8	1.1	1.5	4.75	2.8
	6.0	83.5	0.033	0.073	0.11	0.12	0.31	0.79	1.1	1.65	5.5	2.3
GS302	2.2	97	0.03	0.12	0.21	0.38	0.47	0.73	1.62	-	-	-
	3.0	118	0.027	0.1	0.19	0.3	0.4	0.64	0.9	1.2	3.8	1.9
	4.0	152	0.026	0.058	0.09	0.1	0.25	0.5	0.69	1.05	3.5	2.1
GSL302	4.0	70	0.035	0.084	0.17	0.29	0.38	0.8	-	-	-	-
	5.0	85	0.027	0.08	0.15	0.25	0.3	0.4	0.8	-	-	-
	6.0	104	0.028	0.08	0.12	0.2	0.28	0.36	0.6	-	-	-

VACUUM PUMPS / Green pumps

Dimensions

[Unit : mm]

GS203 / GS252 series

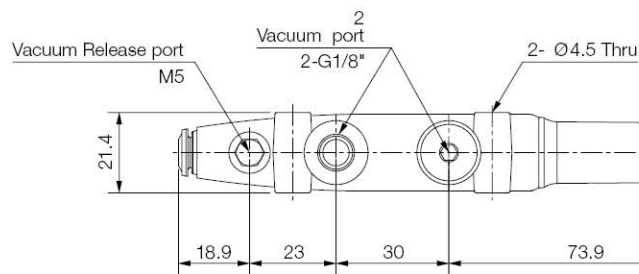
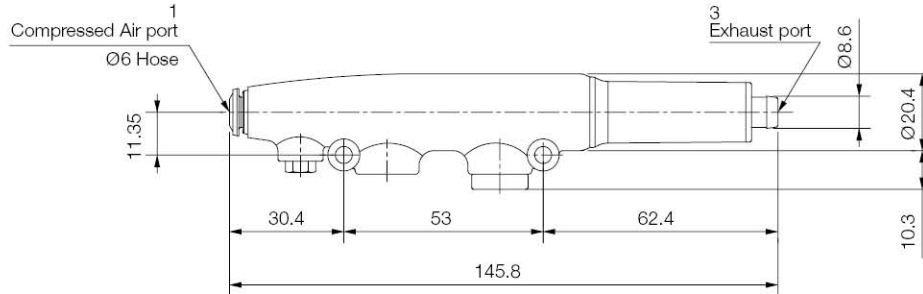

GS253 / GS302 / GSL302 series

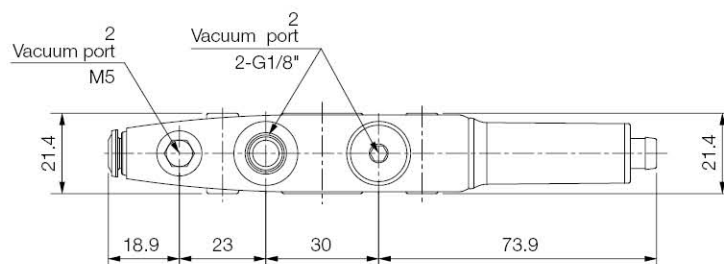
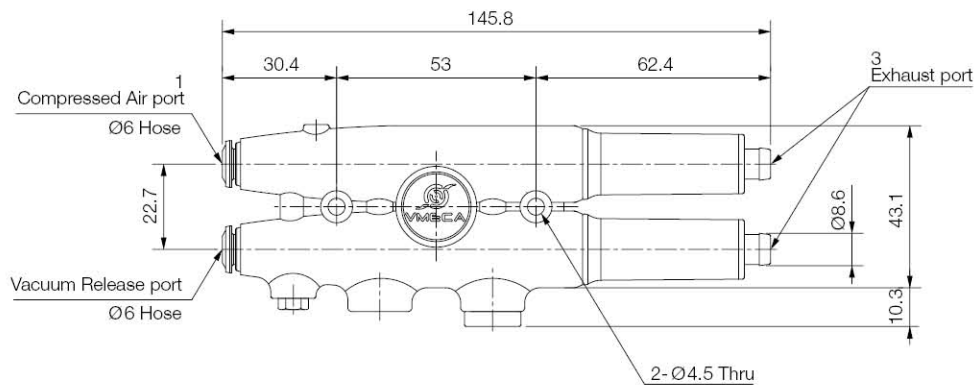

VACUUM PUMPS / Green pumps

GH series

Features and Strengths

- Dual vacuum cartridge structure
- Highly operational reliability despite fluctuating or low compressed-air pressure
- Integrated vacuum filter with high dirt capacity & Auto-cleaning system
- High polished clean surface for food, pharma and chemical industry
- Easy to install in limited space due to compact size
- Quick response time



Specifications

Description	GH203	GH252	GH253	GH302	GHL302
Max. Vacuum level	-90kPa	-94kPa	-94kPa	-92kPa	-75kPa
Open Vacuum flow	172 NI/min	222 NI/min	292 NI/min	343 NI/min	400 NI/min
Max. Feed pressure	4 bar	6 bar	6 bar	4 bar	6 bar
Temperature	-20 ~ 80 °C	-20 ~ 80 °C	-20 ~ 80 °C	-20 ~ 80 °C	-20 ~ 80 °C
Noise level	52 ~ 58 dBA	60 ~ 68 dBA	60 ~ 68 dBA	60 ~ 68 dBA	60 ~ 68 dBA
Weight	0.09Kg	0.095Kg	0.10Kg	0.210Kg	0.210Kg

Vacuum Flow

Model	Max. vacuum (-kPa)	Feed Pressure (bar)	Vacuum flow (NI/min) at different vacuum levels (-kPa)									
			0	10	20	30	40	50	60	70	80	90
GH203	65	2.2	134	59	34	22.4	16	10.4	2.8	-	-	-
	90	3.3	171	73.8	52	31.6	22	17.8	13.2	7.8	4	-
	85	4.0	171	85.4	62	46	28.2	15.2	12.8	7.8	2.6	-
GH252	90	5.0	224	170	126	86	74	54	44	34	22	6.2
	94	5.5	226	182	138	96	60	52	44	34	22	5.6
	94	6.0	222	194	153	108	64	50	42	32	19	4.6
GH253	90	5.0	274	210	126	84	65	52	42	34	22	6.2
	94	5.5	282	218	142	102	64	52	44	35	22	5.6
	94	6.0	292	216	150	120	84	50	42	32	19.2	4.6
GH302	75	2.2	328	245	176	106	63	57	33	9.2	-	-
	92	3.0	340	304	212	128	66	64	44	33	12.8	3.8
	92	4.0	342	308	255	188	138	86	47	34.5	13.8	4.2
GHL302	60	4.0	376	316	220	140	92	56	13	-	-	-
	70	5.0	390	352	260	164	100	75	46	24	-	-
	75	6.0	400	366	308	200	104	76	64	44	-	-

I Evacuation Time

Model	Feed Pressure (bar)	Air Consumption (NI/min)	Evacuation time in sec / liter to reach different vacuum levels (-kPa)									
			0	10	20	30	40	50	60	70	80	90
GH203	2.2	40	0.04	0.19	0.4	0.74	0.95	1.2	-	-	-	-
	3.2	55	0.03	0.14	0.26	0.7	0.7	1	1.6	3	-	-
	4.0	64	0.037	0.13	0.24	0.4	0.5	0.9	1.5	3.4	-	-
GH252	5.0	141	0.019	0.075	0.14	0.24	0.30	0.08	1.04	1.41	2.42	3.1
	5.5	154	0.018	0.065	0.12	0.20	0.27	0.43	0.60	0.80	2.50	2.8
	6.0	167	0.017	0.04	0.06	0.06	0.16	0.41	0.58	0.88	2.90	2.3
GH253	5.0	141	0.017	0.068	0.115	0.21	0.26	0.41	0.91	1.23	2.11	3.1
	5.5	154	0.017	0.062	0.11	0.18	0.25	0.40	0.55	0.75	2.37	2.8
	6.0	167	0.016	0.036	0.05	0.06	0.16	0.39	0.55	0.82	2.75	2.3
GH302	2.2	194	0.018	0.065	0.108	0.2	0.25	0.395	0.81	-	-	-
	3.0	236	0.016	0.05	0.07	0.16	0.23	0.34	0.5	0.795	2.01	1.9
	4.0	304	0.014	0.029	0.043	0.05	0.13	0.25	0.355	0.71	1.75	2.1
GHL302	4.0	140	0.018	0.04	0.08	0.145	0.195	0.5	-	-	-	-
	5.0	170	0.014	0.036	0.075	0.125	0.16	0.25	0.45	-	-	-
	6.0	208	0.013	0.032	0.06	0.1	0.155	0.2	0.35	-	-	-

VACUUM PUMPS / Green pumps

I Dimensions

[Unit : mm]

GH203 / GH252 series

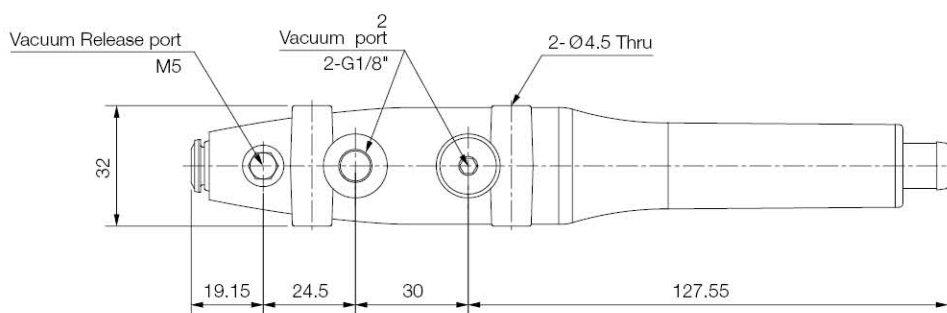
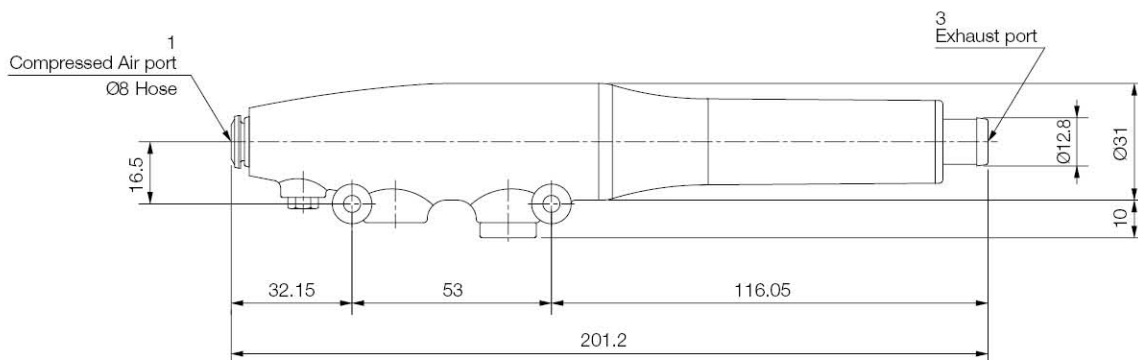

GH253 / GH302 / GHL302 series

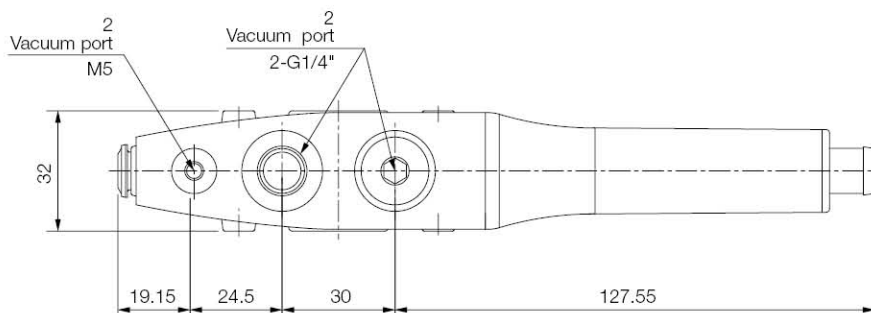
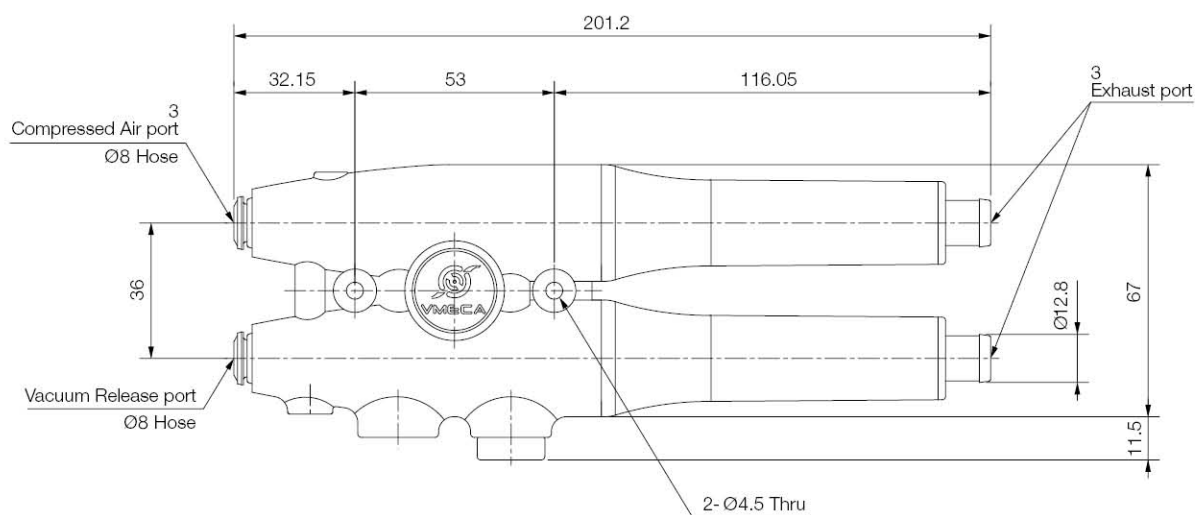

VACUUM PUMPS / Green pumps

I Build an Ordering No.

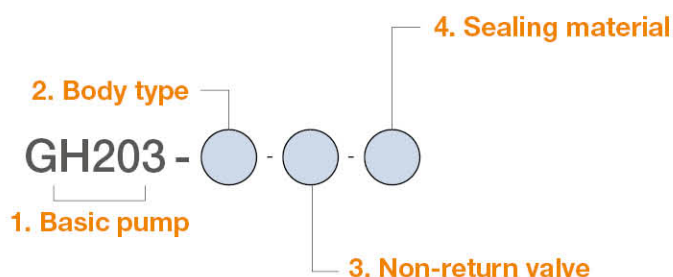

1. Basic pump	Description	Symbol
	Green pump, Mini 3-stage with vacuum filter	GS203F
	Green pump, Mini premium 2-stage without vacuum filter	GS252
	Green pump, Mini premium 3-stage with vacuum filter	GS253F
	Green pump, Midi 2-stage without vacuum filter	GS302
	Green pump, Midi "L" type 2-stage without vacuum filter	GSL302
	Green pump, Dual cartridge, Mini 3-stage with vacuum filter	GH203F
	Green pump, Dual cartridge, Mini premium 2-stage without vacuum filter	GH252
	Green pump, Dual cartridge, Mini premium 3-stage with vacuum filter	GH253F
	Green pump, Dual cartridge, Midi 2-stage without vacuum filter	GH302
	Green pump, Dual cartridge, Midi "L" type 2-stage without vacuum filter	GHL302
2. Body type	Description	Symbol
	Opaque body	A
	Transparent body	B
3. Non-return valve	Description	Symbol
	No non-return valve	Blank
	Non-return valve	N
4. Sealing material	Description	Symbol
	NBR	Blank
	VITON	V
	EPDM	E

I Spare Parts – Basic pumps

Model	Description	Weight (g)
GS203F-A	Green pump, Mini 3-stage with vacuum filter, Opaque body	60.3
GS252-A	Green pump, Mini premium 2-stage without vacuum filter, Opaque body	67
GS253F-A	Green pump, Mini premium 3-stage with vacuum filter, Opaque body	111.5
GS302-A	Green pump, Midi 2-stage without vacuum filter, Opaque body	119.5
GSL302-A	Green pump, Midi "L" type 2-stage without vacuum filter, Opaque body	118
GH203F-A	Green pump, Dual cartridge, Mini 3-stage with vacuum filter, Opaque body	122.6
GH252-A	Green pump, Dual cartridge, Mini premium 2-stage without vacuum filter, Opaque body	135.1
GH253F-A	Green pump, Dual cartridge, Mini premium 3-stage with vacuum filter, Opaque body	123.9
GH302-A	Green pump, Dual cartridge, Midi 2-stage without vacuum filter, Opaque body	205
GHL302-A	Green pump, Dual cartridge, Midi "L" type 2-stage without vacuum filter, Opaque body	204
GS203F-B	Green pump, Mini 3-stage with vacuum filter, Transparent body	60.3
GS252-B	Green pump, Mini premium 2-stage without vacuum filter, Transparent body	67
GS253F-B	Green pump, Mini premium 3-stage with vacuum filter, Transparent body	111.5
GS302-B	Green pump, Midi 2-stage without vacuum filter, Transparent body	119.5
GSL302-B	Green pump, Midi "L" type 2-stage without vacuum filter, Transparent body	118
GH203F-B	Green pump, Dual cartridge, Mini 3-stage with vacuum filter, Transparent body	122.6
GH252-B	Green pump, Dual cartridge, Mini premium 2-stage without vacuum filter, Transparent body	135.1
GH253F-B	Green pump, Dual cartridge, Mini premium 3-stage with vacuum filter, Transparent body	123.9
GH302-B	Green pump, Dual cartridge, Midi 2-stage without vacuum filter, Transparent body	205
GHL302-B	Green pump, Dual cartridge, Midi "L" type 2-stage without vacuum filter, Transparent body	204